

HOSETRACT

HOSE REELS

Inlet — 1/2" FPT Max. Temp. — 200°F

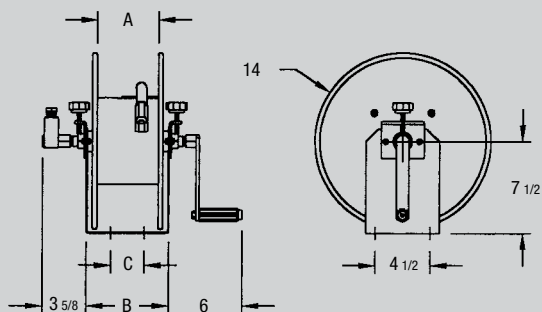

All reels shipped less hose unless requested on quote basis.

Mounting holes 1/2" dia.

SERIES	DIMENSIONS		
	A	B	C
M 5-5-14	5	7	2 3/4
M 10-5-14	10	12	7 3/4



For 3/8" and 1/2" Hose I.D.

M Series Mini

COMPACT MANUAL DRIVEN MINI-REEL. REEL is best applied where a maximum of 150 ft. of 3/8" I.D. hose is required, and where space or weight is a critical factor. This products is ideally fitted into tight space applications such as small truck skid units for pesticides, pressure wash or deployment of air tools in the construction trades.

FEATURES

- Beaded edges on spool prevents hose damage or injury to operator
- Heavy 12 GA. base
- Heavy duty ABS bearings require no lubrication for years of dependable service
- Fully adjustable brake - adjust with hand knob
- Only 14 1/2" tall
- External swivel-O-rings can be changed by simply removing one retaining ring

Model Number	Operating Pressure	Capacity Hose I.D.		Shipping Weight
		3/8"	1/2"	
M 5-5-14	4000 PSI	75 FT.	50 FT.	20#
M 10-5-14	4000 PSI	150 FT.	100 FT.	23#

M Series Mini Hose Reels also available in stainless steel. Call factory for more details.



Hosetract Industries, LTD. • P: 260.489.8828 • F: 260.489.6088

HOSETRACT 