

HOSETRACT

HOSE REELS

All reels shipped less hose unless requested on quote basis.

Inlet — 5 - 1/2" FPT Max. Temp. — 200°F
10 - 1" FPT

Mounting holes 1/2" dia.

SERIES	DIMENSIONS		
	A	B	C
E15	15	18½	19½
E20	20	23½	24½
E25	25	28½	29½

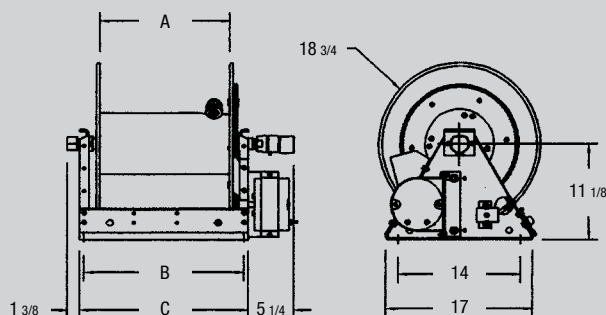

For 3/8", 1/2", 3/4", and 1" Hose I.D.

E Series

12V DC MOTOR DRIVEN HOSE REELS

For applications in the Lawn Care, Agricultural, Service Truck and many Industrial applications.

FEATURES

- Motor sprocket and chain pinch points are safe guarded
- Flow through shaft for universal installation
- Self lubricating ABS bearings
- External swivel - standardized O-rings can be changed by simply removing one retaining ring
- Motor bracket assembly allows ease of chain tightening
- Prewire option available
- Mounting base is light and strong

12V DC Motor Driven for 3/8" & 1/2" Hose

Model Number	Operating Pressure	Capacity Hose I.D.		Shipping Weight
		3/8"	1/2"	
E 15-5	4000 PSI	350 FT.	275 FT.	64#
E 20-5	4000 PSI	450 FT.	375 FT.	68#
E 25-5	4000 PSI	550 FT.	475 FT.	72#

12V DC Motor Driven for 3/4" and 1" Hose

Model Number	Operating Pressure	Capacity Hose I.D.		Shipping Weight
		3/4"	1"	
E 15-10	300 PSI	100 FT.	75 FT.	66#
E 20-10	300 PSI	125 FT.	100 FT.	70#
E 25-10	300 PSI	150 FT.	125 FT.	74#

Guide system available for 10", 15", 20", 25" wide reels. sold separately (page 20).
Reel can be factory prewired at additional cost. E Series Reel must be shipped by truck only.



Hostract Industries, LTD. • P: 260.489.8828 • F: 260.489.6088